

See page 5 for Critical Mounting Dimension!



# Magnetic Drive Gear Pump

## Installation / Operation Manual

### Model Numbers Covered:

DF-A483-T    DTP-A127-T    SST-A127-T  
DT-A127-T    DTP-A356-T    SST-A190-T  
DT-A356-T    DTP-A483-T    SST-A356-T  
DT-A483-T

*\*Disassembly of Pump Voids Warranty\**

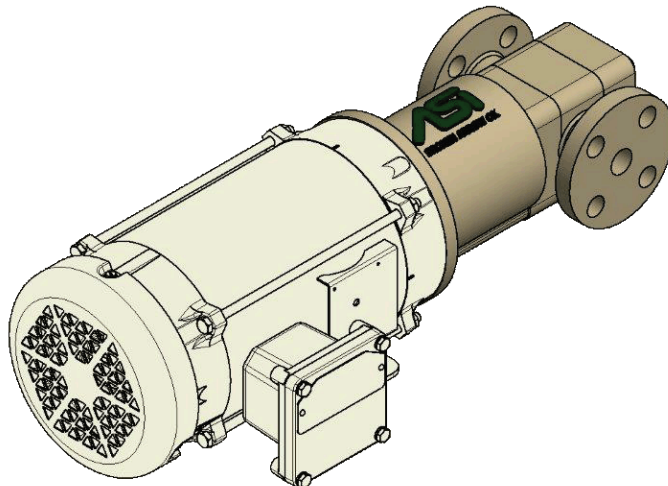

ADDITIVE SYSTEMS INC.  
407 S. Main St • Broken Arrow OK, 74012  
[www.additivesystems.com](http://www.additivesystems.com)  
1-800-324-1420  
"Since 1984"



## Table Of Contents

### Page #

**3.....Overview**  
**4.....Features - Specifications**  
**5.....Magnetic Coupling - Pump Mounting**  
**6.....Rotation - Pressure Relief Valve**  
**7.....Piping**  
**8.....Typical Installation Illustration**  
**9 & 10.....Start up Checklist - Trouble Shooting**  
**11-22 ....Performance Curves**  
**23.....Warranty**

### Pick the right pump for your application

|   | Standard Duty<br>Ductile Iron | High<br>Pressure | Heavy Duty<br>SS Hammer |
|---|-------------------------------|------------------|-------------------------|
| Oxygenates                              |                               |                  | X                       |
| Dyes (i.e. diesel and product tracking) |                               |                  | X                       |
| Gasoline                                |                               |                  | X                       |
| Fuel Additives                          | X                             |                  |                         |
| Pipeline Sampling                       |                               | X                |                         |
| Diesel                                  | X                             | X                |                         |
| Liquid Gas Products                     |                               |                  | X                       |
| Jet fuels                               | X                             | X                |                         |
| Fertilizers                             | X                             | X                |                         |
| Chemicals                               |                               |                  | X                       |
| Withstand static PSI up to 100 PSI      | X                             | X                | X                       |
| Withstand static PSI up to 2800 PSI     |                               | X                |                         |

### Optional Equipment

|                |                                       |
|----------------|---------------------------------------|
| PB-100         | Galvanized Pump Base                  |
| PP-111C-0      | Standard Outer Magnetic Coupling      |
| PP-211C-0      | High Pressure Outer Magnetic Coupling |
| PP-111C-0-145T | Outer Coupling for 145T Motor         |

### “Get Other Items From ASI”

|                       |              |                      |
|-----------------------|--------------|----------------------|
| Freestanding Rack     | Storage Tank | ASCO® Solenoid Valve |
| Pressure Relief Valve | Sight Guage  | Check Valves         |
| Thermal Relief Kit    | Ball Valve   | Swagelok® Fittings   |

## Operation

The pumps covered in this manual are positive displacement, external gear, rotary pumps. These pumps use a synchronous magnetic coupling to transfer torque from the drive motor to the pump. This arrangement allows for the elimination of mechanical shaft seals.

ASI pumps are built to precision tolerances from the finest materials. Every pump is performance tested before shipment. When properly installed and maintained it will give long and dependable service. The following pages contain important information for proper Installation and operation.

## Theory Of Operation

External gear pumps use two identical gears rotating against each other -- one gear is driven by a motor and it in turn drives the other gear. Each gear is supported by a shaft with bearings on each side of the gear.

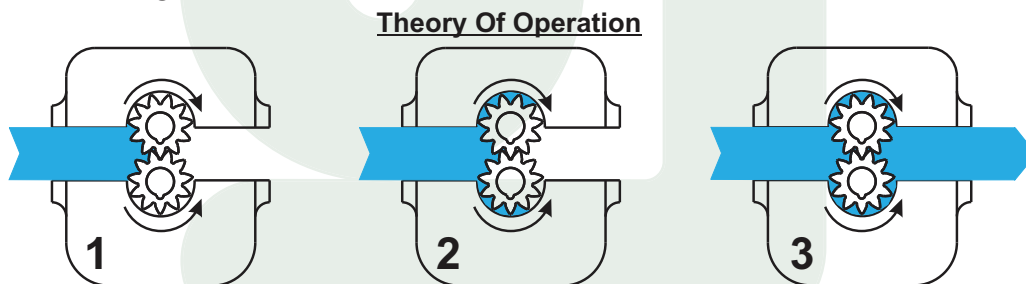

1. As the gears come out of mesh, they create expanding volume on the inlet side of the pump. Liquid flows into the cavity and is trapped by the gear teeth as they rotate.
2. Liquid travels around the interior of the casing in the pockets between the teeth and the casing -- it does not pass between the gears.
3. Finally, the meshing of the gears forces liquid through the outlet port under pressure.

Because the gears are supported on both sides, external gear pumps are quiet-running and are routinely used for high-pressure applications such as hydraulic applications. With no overhung bearing loads, the rotor shaft can't deflect and cause premature wear.

## FEATURES

1. Ductile Iron Construction - Standard
2. Carbon Graphite Bearings.
3. Balanced Magnetic Coupling.
4. Double - Sealed Containment Shell
5. All Teflon Seals
6. \* Consult ASI for speeds greater than 1800 RPM

|                               | <b>Port Connections</b>                   | <b>Nominal Capacity @ 1800 RPM</b> |
|-------------------------------|---|------------------------------------|
| Standard Duty<br>Ductile Iron | DF-A483-T 3/4" 300# ANSI Flat Face Flange | - 8 GPM                            |
|                               | DT-A127-T 1/2" NPT                        | - 2 GPM                            |
|                               | DT-A356-T 3/4" NPT                        | - 5 GPM                            |
|                               | DT-A483-T 3/4" NPT                        | - 8 GPM                            |
| High Pressure                 | DTP-A127-T 1/2" NPT                       | - 2 GPM                            |
|                               | DTP-A356-T 3/4" NPT                       | - 5 GPM                            |
|                               | DTP-A483-T 3/4" NPT                       | - 8 GPM                            |
| Heavy Duty<br>SS Hammer       | SST-A127-T 1/2" NPT                       | - 2 GPM                            |
|                               | SST-A190-T 1/2" NPT                       | - 3 GPM                            |
|                               | SST-A356-T 3/4" NPT                       | - 5 GPM                            |

## Magnetic Coupling

- Do not attempt to drive or force coupling in place. After coupling is in place to dimension, secure to shaft with the two set screws. *See page 5 for Critical Mounting Dimension.*
- Verify that the key does not extend into the open area inside the outer coupling, this will cause the key to rub the pumps containment shell.

**CAUTION:** Do not install unattached coupling into pump housing. Magnetic force will make removal difficult. Inspect magnets for any metallic debris. Remove any foreign material. Place key into keyway slot on motor shaft. A light film of Anti-Seize lubricant over the motor shaft will help prevent Corrosion. Slip coupling over shaft to the specified dimension. (see page 5) If coupling will not slip easily over shaft, it may be necessary to file off a small amount of material from two sides of the key. This is due to plating buildup in keyway of coupling.

## NEMA 56C Motor

### *Critical Mounting Dimension*

*Failure to install the outer magnetic coupling at the proper distance of 4 9/16" from the face of the motor will severely hamper the life of your motor, pump, and magnetic coupling. While this critical dimension is easy to achieve, it is vital to the life of your equipment.*

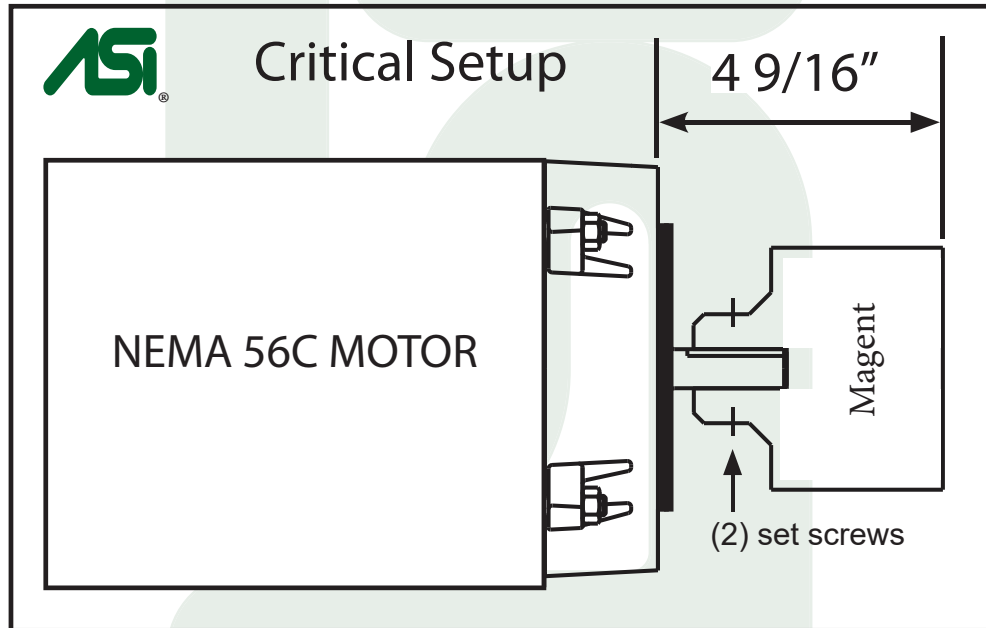

### **Pump To Motor Mounting**

*CAUTION: Keep hands and fingers clear of mating surfaces when assembling pump to motor. Carefully guide pump and housing assembly over outer coupling toward motor. As coupling magnets align they will rapidly pull pump and motor assembly together. Secure housing to motor with the four (4) 3/8" socket head cap screws provided.*

### **Pump Mounting**

1. Pump and motor assembly should be mounted securely to a solid base.
2. Mount pump as close to liquid supply as possible. Locate pump below liquid level
3. If possible. The better the suction conditions the better the pump will perform.

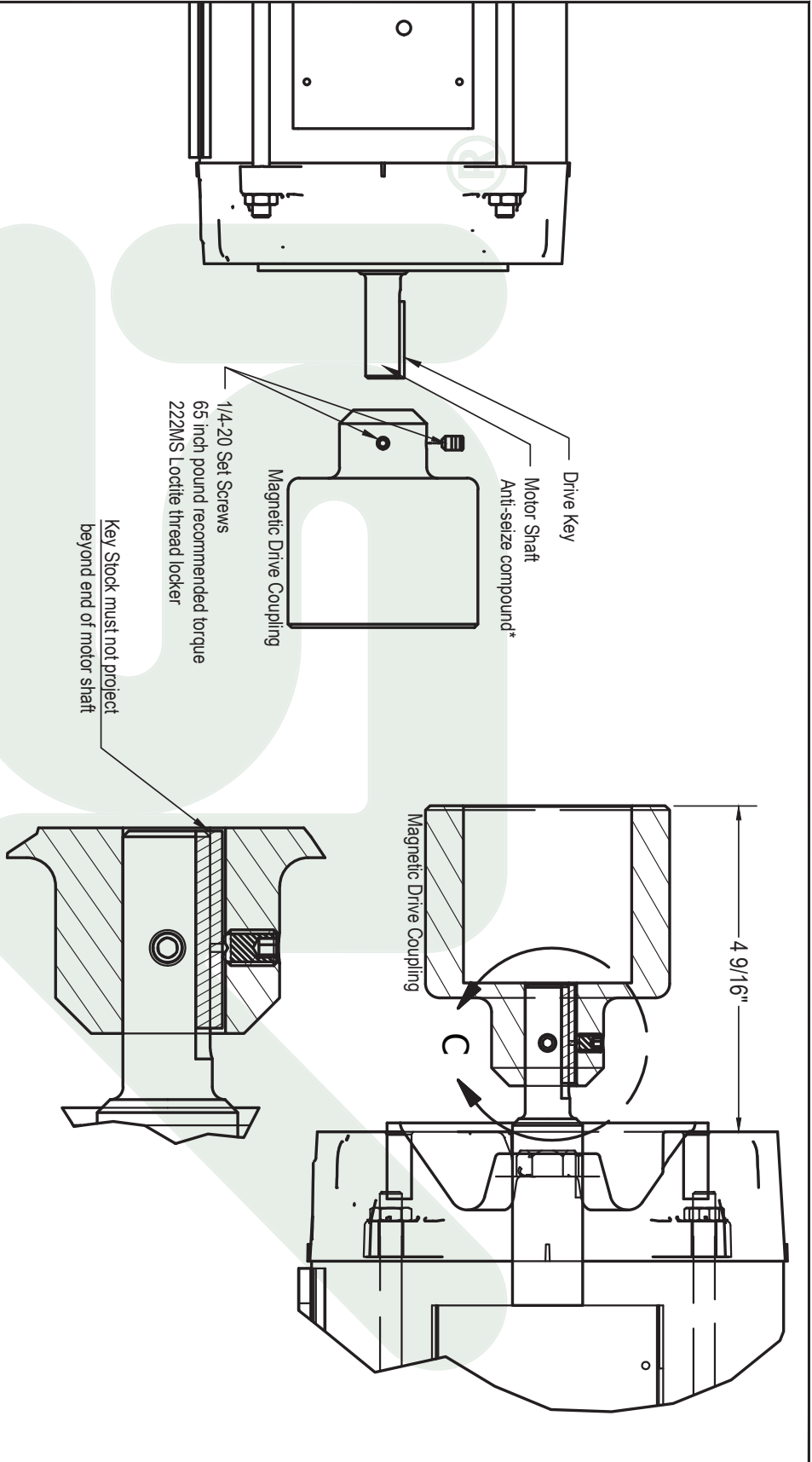

**Magnetic Drive Pump Coupling Supplemental Information:**

- \* Refer to pump manual for additional information regarding pump installation and start up.
- \* ASI recommends the use of a commercially available Anti Seize\* compound on motor shaft and a low strength thread locker on set screws.
- \* Place a small amount of Anti Seize compound on motor shaft before installing pump coupling.
- \* This will help eliminate corrosion and aid in coupling removal in the future.
- \* After the coupling is installed to the 4-9/16" dimension verify the motor drive key does not extend beyond the end of the motor shaft. A key that extends beyond motor shaft has the potential to contact the end of the containment barrier causing wear and a potential leak.
- \* A low strength thread locker applied to each set screw will prevent the set screws from loosening over time due to vibration and thermal expansion. \* Loctite 222MS is a good choice.

**Pump Magnetic Coupling Installation**

|  |               |             |
|--|---------------|-------------|
| SCALE                                      | DATE 02/24/17 | EDIT DATE   |
| Coupling Install Detail - Supplemental     |               |             |
| Revision March 2017                        |               |             |
| W/O#                                       | Drawing #     | Rev.        |
| Additive Systems Inc.<br>Broken Arrow, OK. |               | DRAWN BY JF |

Sheet 1 of 1

## Rotation

These pumps are designed for clockwise rotation. (Viewed from motor end of pump)

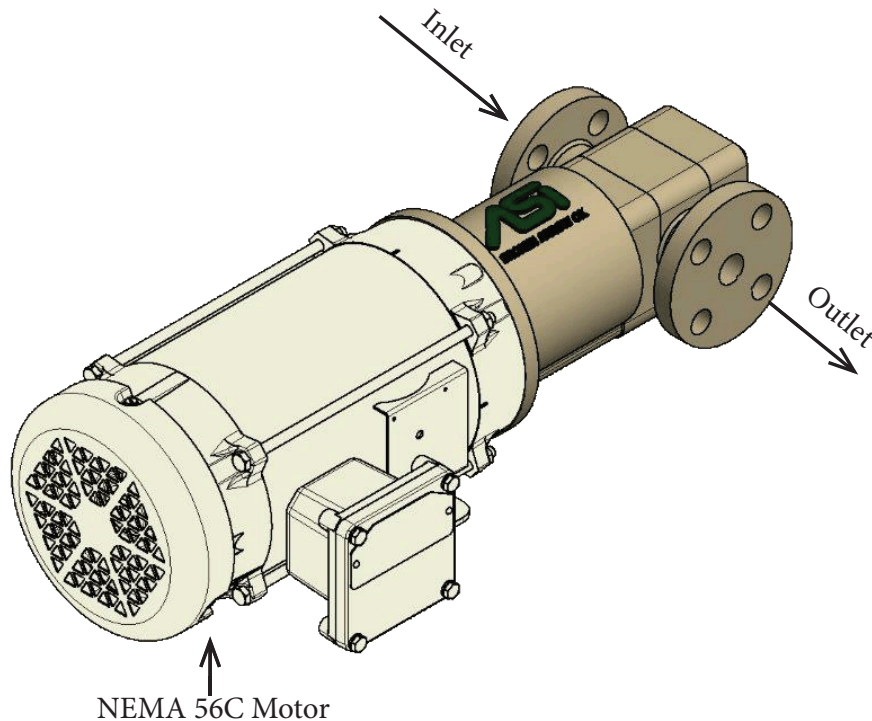

## Pressure Relief Valve

All Pumps covered in this manual are positive displacement type and require an external pressure control valve rated for the pumps maximum flow rate in the discharge line.

The pressure control valve provides over pressure protection for the pump and related piping.

The control valve will also maintain correct operating pressure in the system.

## **Piping**

1. Select piping equal to or larger than the port connections. Check inside of piping for debris.
2. Suction piping should be as short and direct as possible. Suction piping should be one size larger than the port size.
3. Install a strainer of adequate size in supply line. A supply of clean liquid is imperative for pump longevity. Select a strainer with a mesh size large enough not to restrict flow, but small enough to protect pump. Forty or sixty mesh screen is acceptable.
4. Install pressure control valve and pressure gauge in the discharge line.
5. The pressure gauge is necessary to monitor operating pressure and control valve setting.
6. Do not use the pump to support piping. Use hangers, stands or other means to support the piping.
7. Piping should fit without imposing strain on the pump casing. Strain or distortion on the pump casing can cause mis-alignment and rapid wear of the pump components.
8. Pipe connections must be tight. Thread sealant and or teflon tape will help eliminate leaks. If using teflon tape be careful not to over tighten fittings causing damage.

## **RETURN PIPING SAFETY STATEMENT**

ASI highly recommends installing return piping from pressure control valve back to the storage tank.

This practice will:

- Help dissipate heat
- Help circulate/agitate the product in the tank.
- Prolong life of pump
- Prolong life of tank
- Minimize risk of exceeding flash point on more volatile chemicals

In general, you need to dissipate the heat as much as possible. If you can't dissipate the heat it will continue building temperature as long as the pump is running. In some instances, it can exceed the flash point on some of the more volatile chemicals. See below for layout of a "typical additive pump installation".

**WARNING:** The danger in returning directly to the (upstream) suction line is the heat gets added to the gear pump (from just running & circulating) doesn't get a chance to dissipate like it does if you return back to the tank.

# Typical Additive Pump Installation

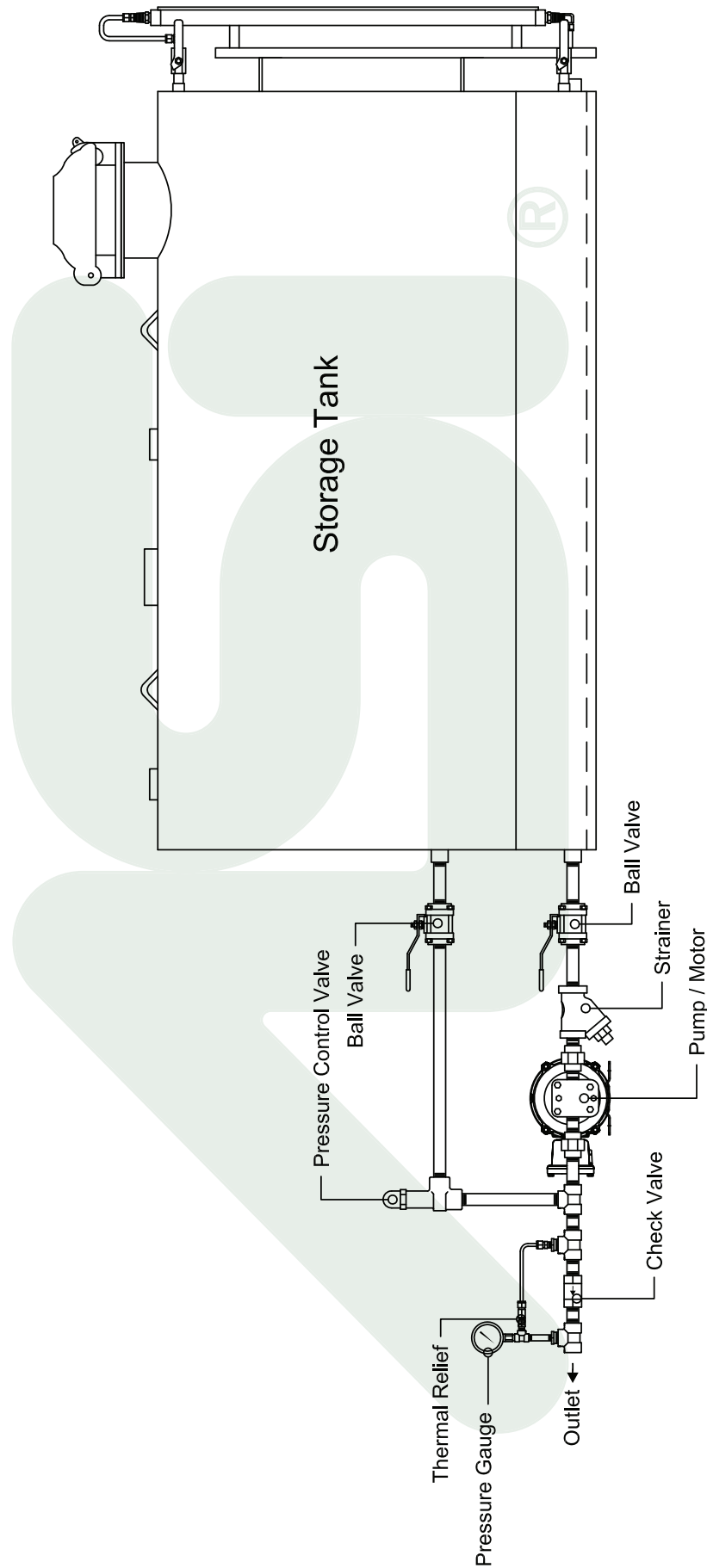

## Temperature Min/Max Range

### All ASI Pumps

Maximum operating temperature: 250° F

Minimum operating temperature: -25°F

## Startup Check List



### Before starting pump check the following:

1. Control valve, pressure gauge and strainer are in place.
2. All pipe connections are tight.
3. Pump rotates freely.
4. All valves are open.
5. Motor rotation is correct.
6. Pump has adequate liquid supply.

### **STARTUP**

After starting, pump should begin to deliver liquid within 10 to 20 seconds. If not, shut off pump and go through previous check list.

## TROUBLE SHOOTING

If pump does not deliver liquid - probable causes:

1. Clogged strainer.
2. Rotation is reversed.
3. Valves are closed.
4. Air pockets or vapor locked.
5. Low tank level.
6. Pressure relief piston stuck or is set too low.
7. Suction lift too high.

## PUMP EXCESSIVELY NOISY

### **PROBABLE CAUSES:**

1. Vibration due to pump and / or piping mounting. Anchor mounting base and piping.
2. Pump cavitation or starved.
  - Strainer clogged.
  - Suction piping too small.
  - Suction lift too high.
  - Pump speed too high for viscosity of liquid.

**PUMP CAPACITY LOW**

**Probable causes:**

1. Strainer clogged.
2. Air leaks in suction piping.
3. Motor running too slow.
4. Relief valve set too high.
5. Valves partially closed.
6. Excessive clearance in pump caused by corrosion or abrasives in liquid.

**CAUTION!**

**Before servicing or removal of pump verify the following:**

1. Liquid supply is shut off.
2. Liquid in the pump can be contained.
3. Drive motor has been disconnected or locked out.

For service or parts please contact your distributor or ASI directly at:

**Additive Systems Inc.  
407 S. Main  
Broken Arrow, OK. 74012  
Ph. 1-800-324-1420  
Fax 918-251-3172  
www.additivesystems.com**

**\*Disassembly of Pump Voids Warranty\***

## SST-A190-T

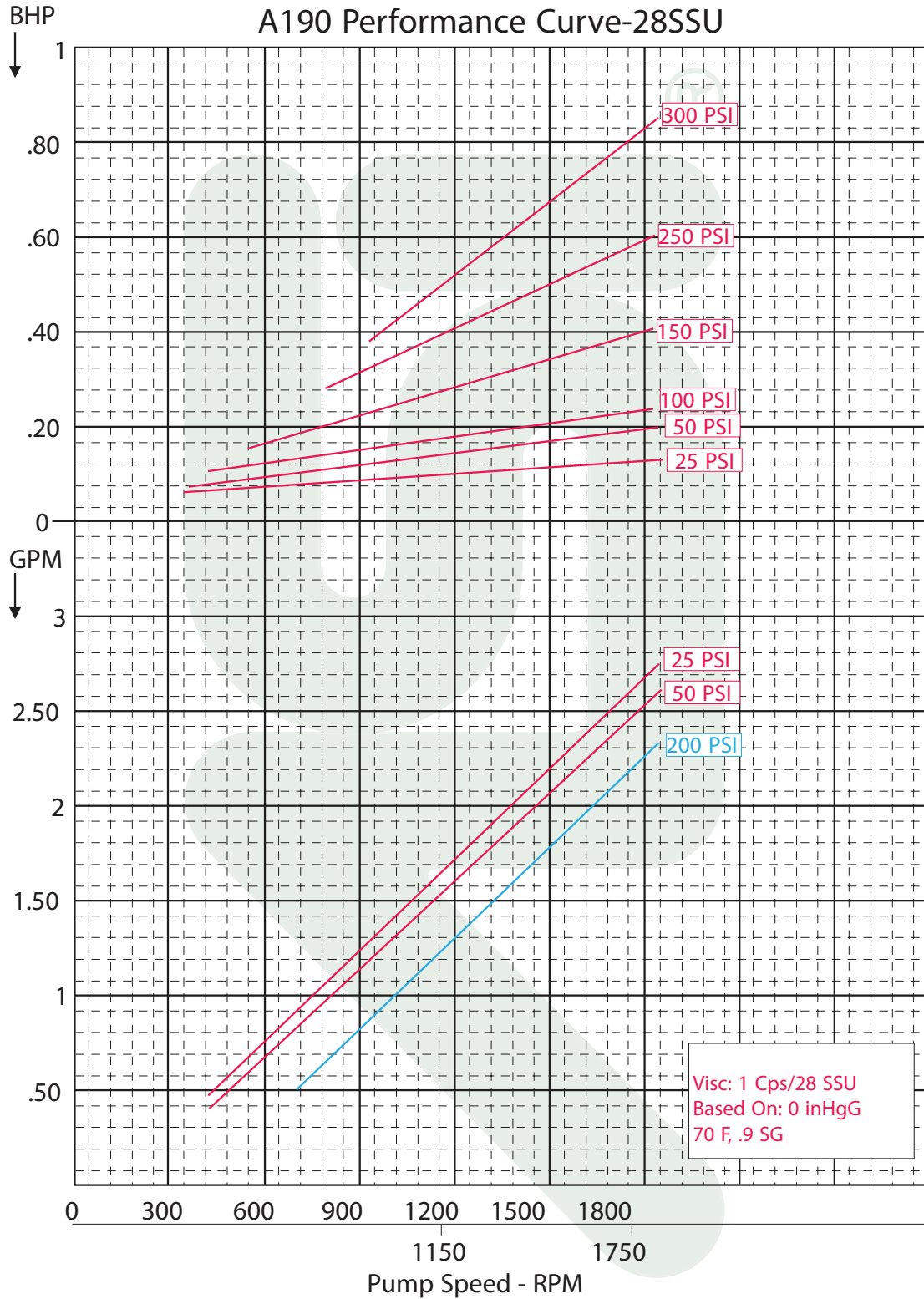

**SST-A190-T**

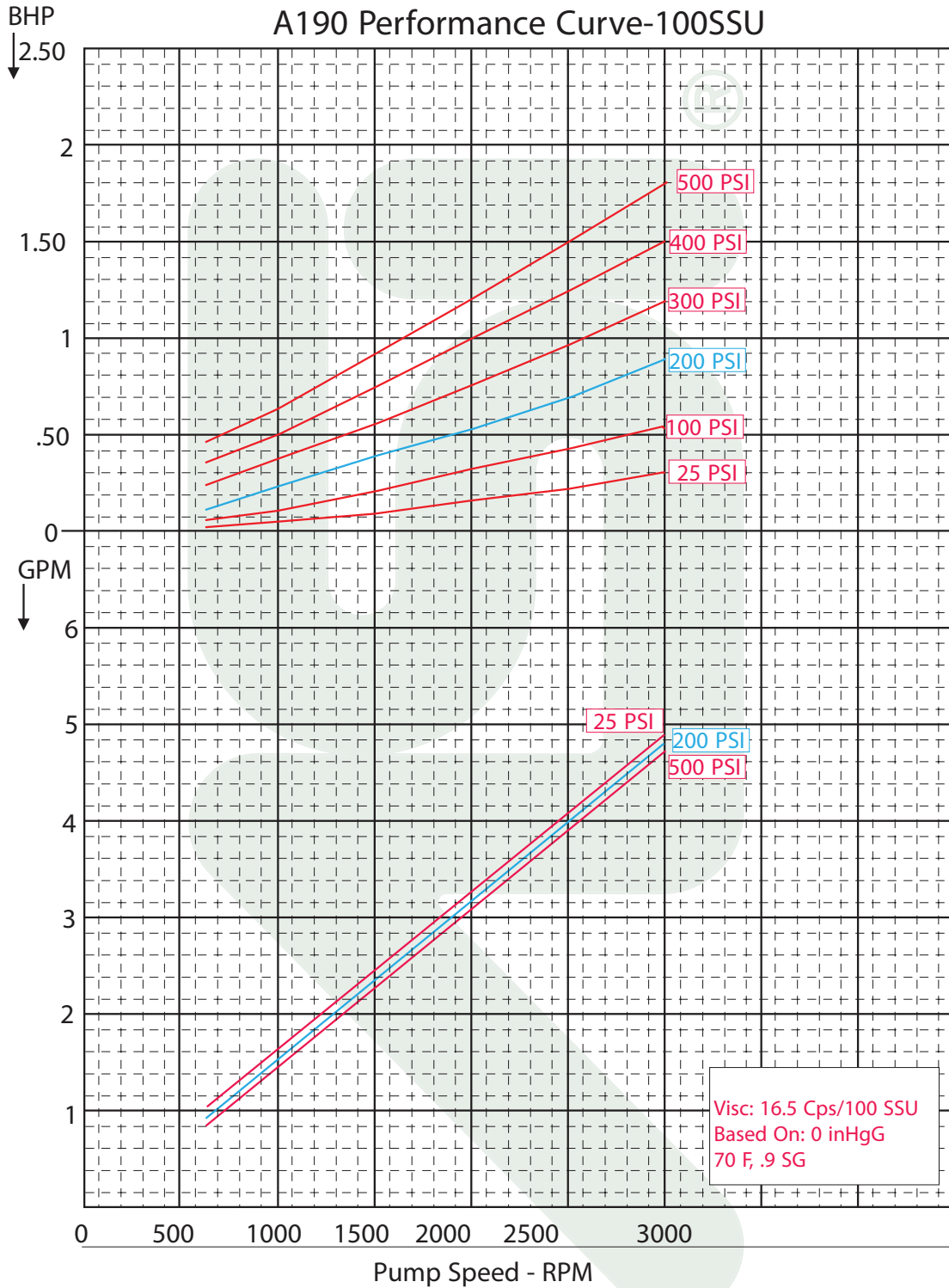

**SST-A190-T**

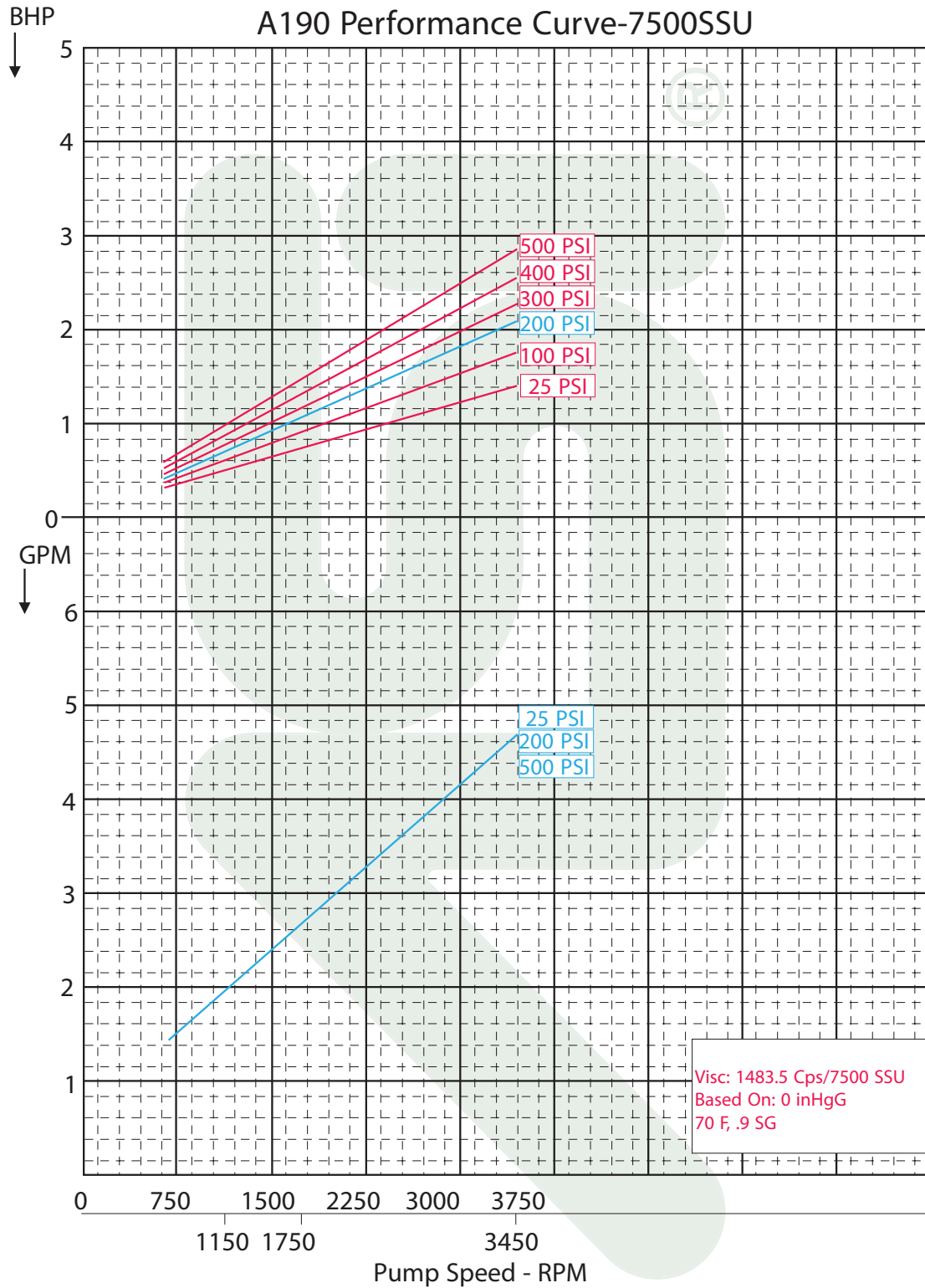

## DT-A127-T / DTP-A127-T/SST-A127-T

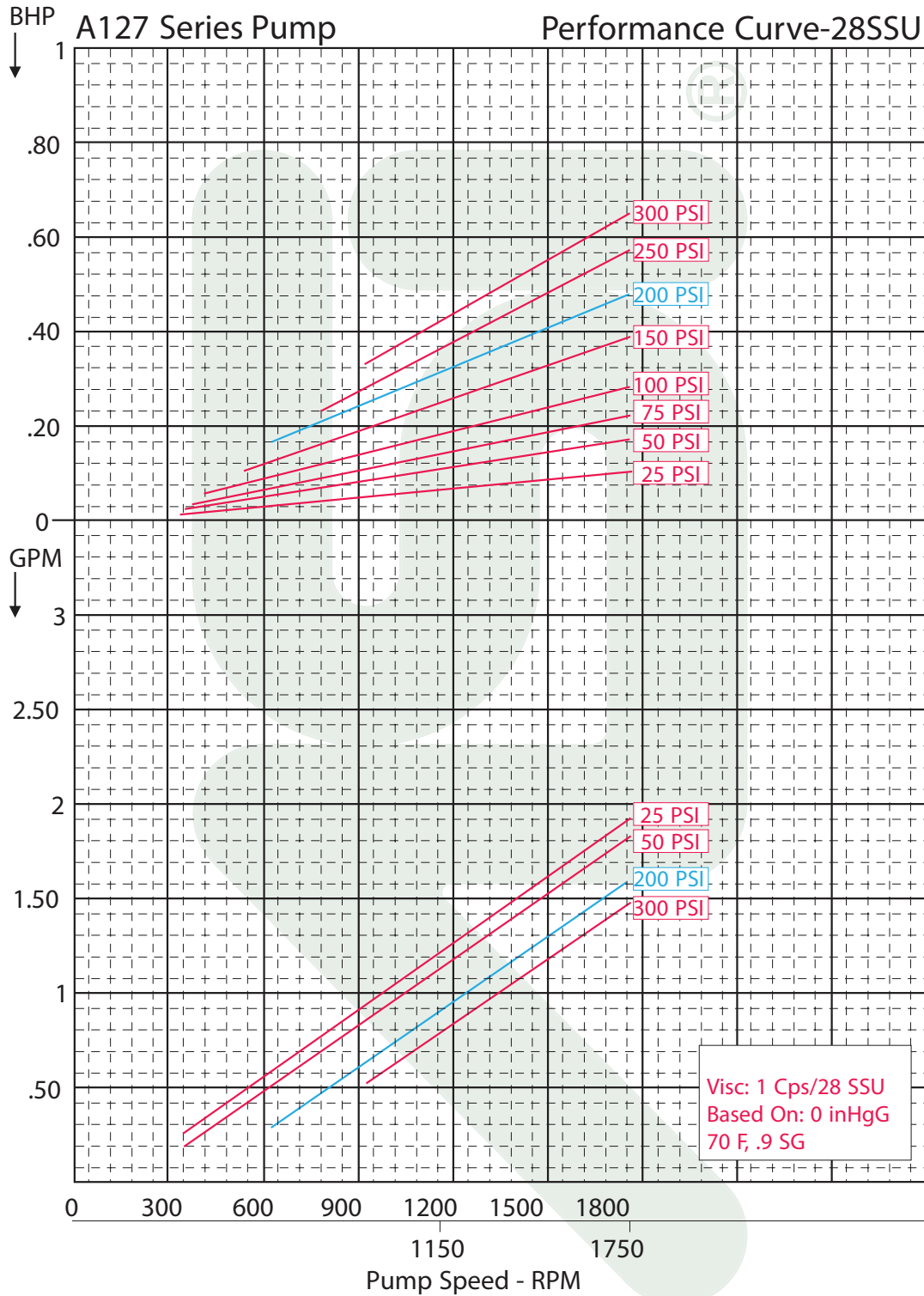

## DT-A127-T / DTP-A127-T/SST-A127-T

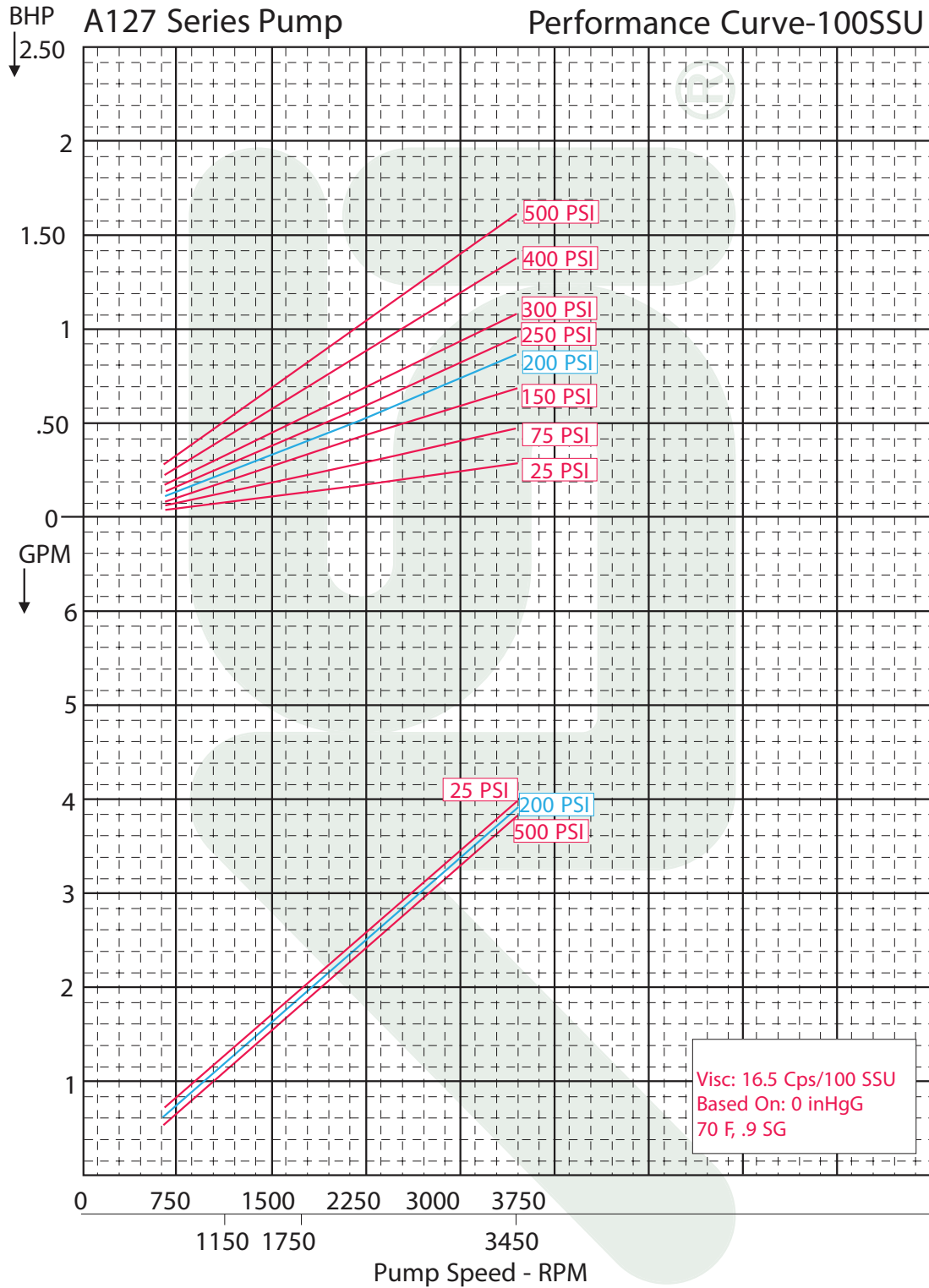

**DT-A127-T / DTP-A127-T/SST-A127-T**

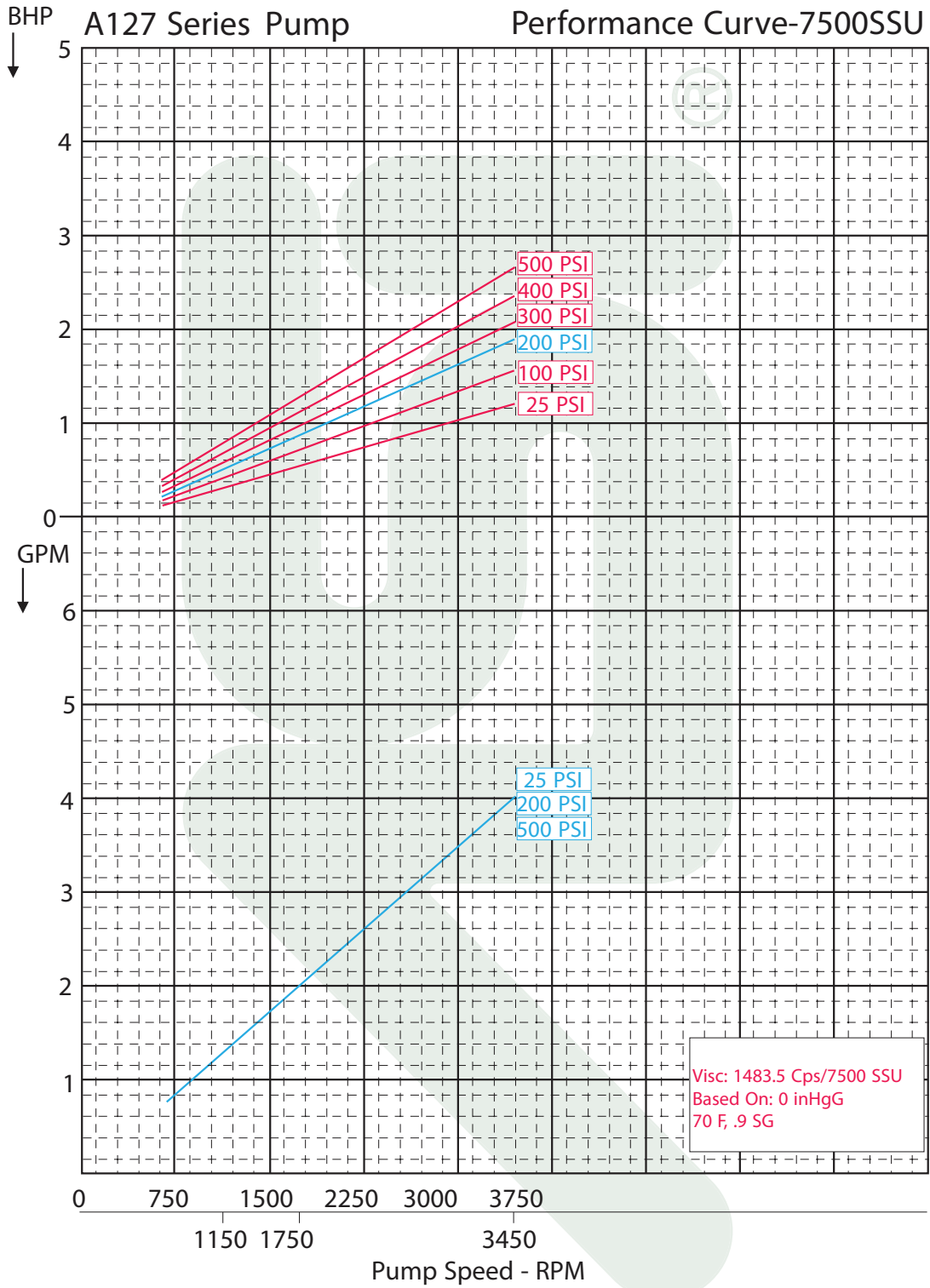

## DT-A356-T / DTP-A356-T / DTS-A356-T / SST-A356-T

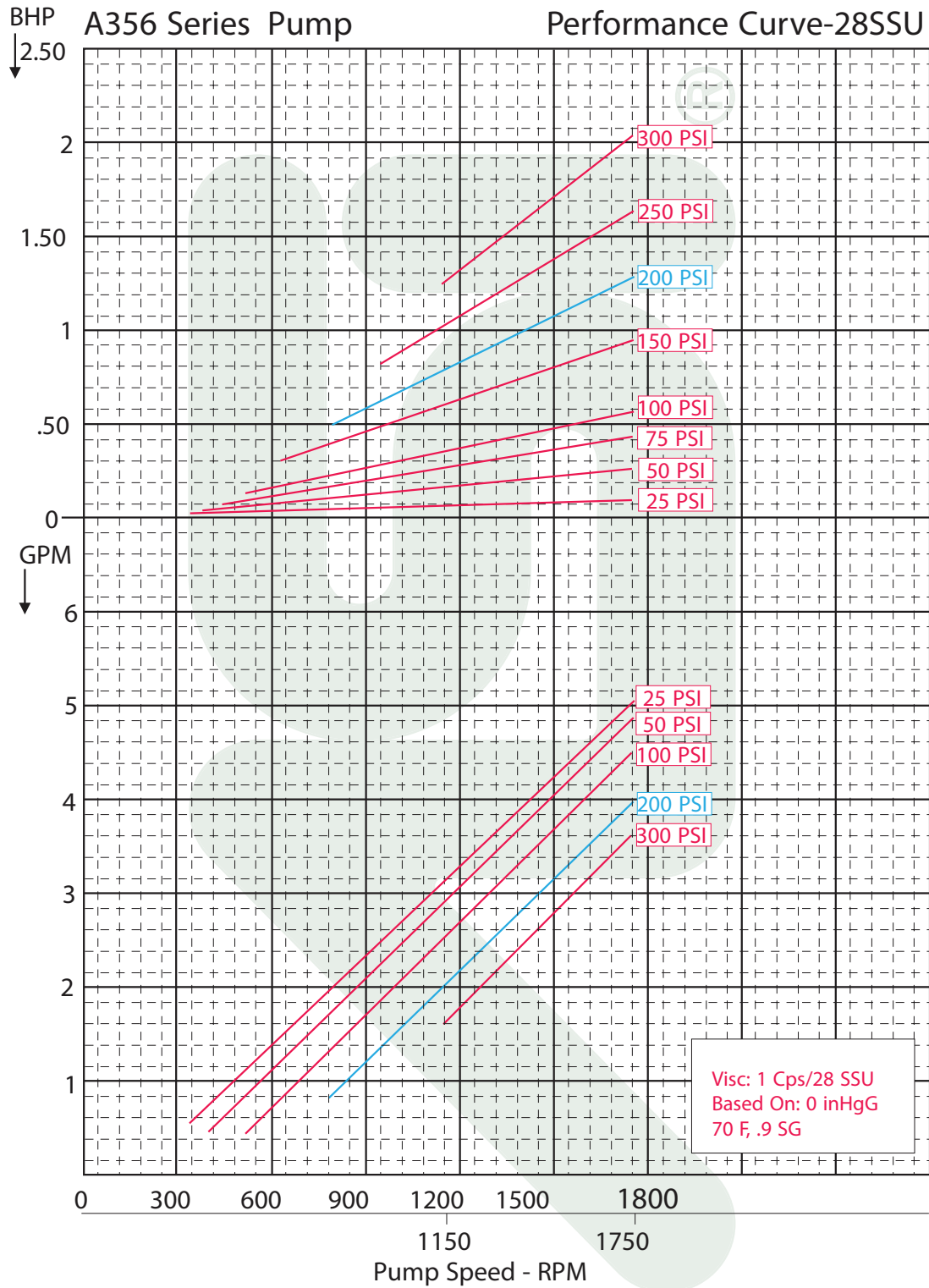

## DT-A356-T / DTP-A356-T / SST-A356-T

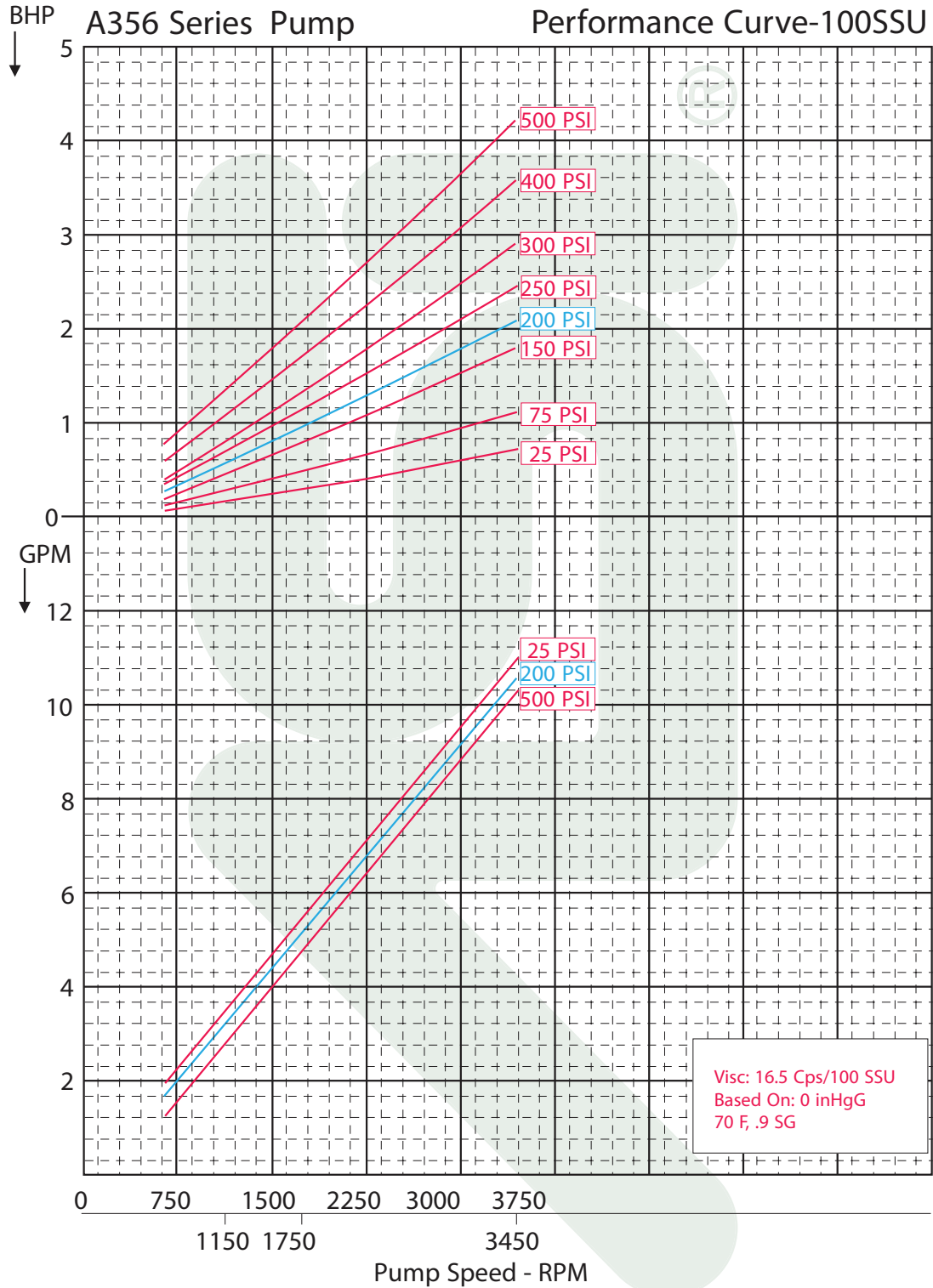

## DT-A356-T / DTP-A356-T / SST-A356-T

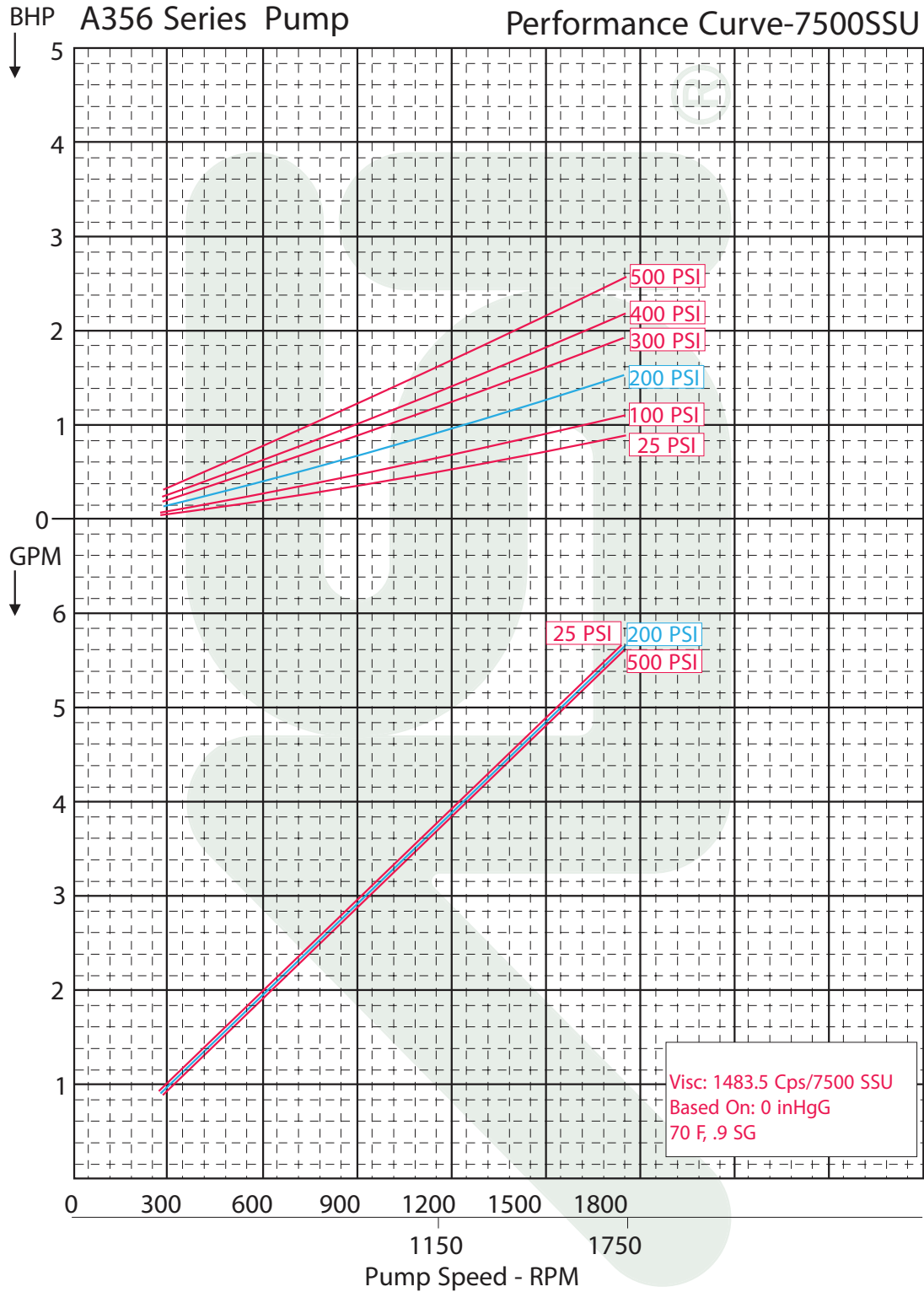

## DF-A483-T / DT-A483-T / DTP-A483-T

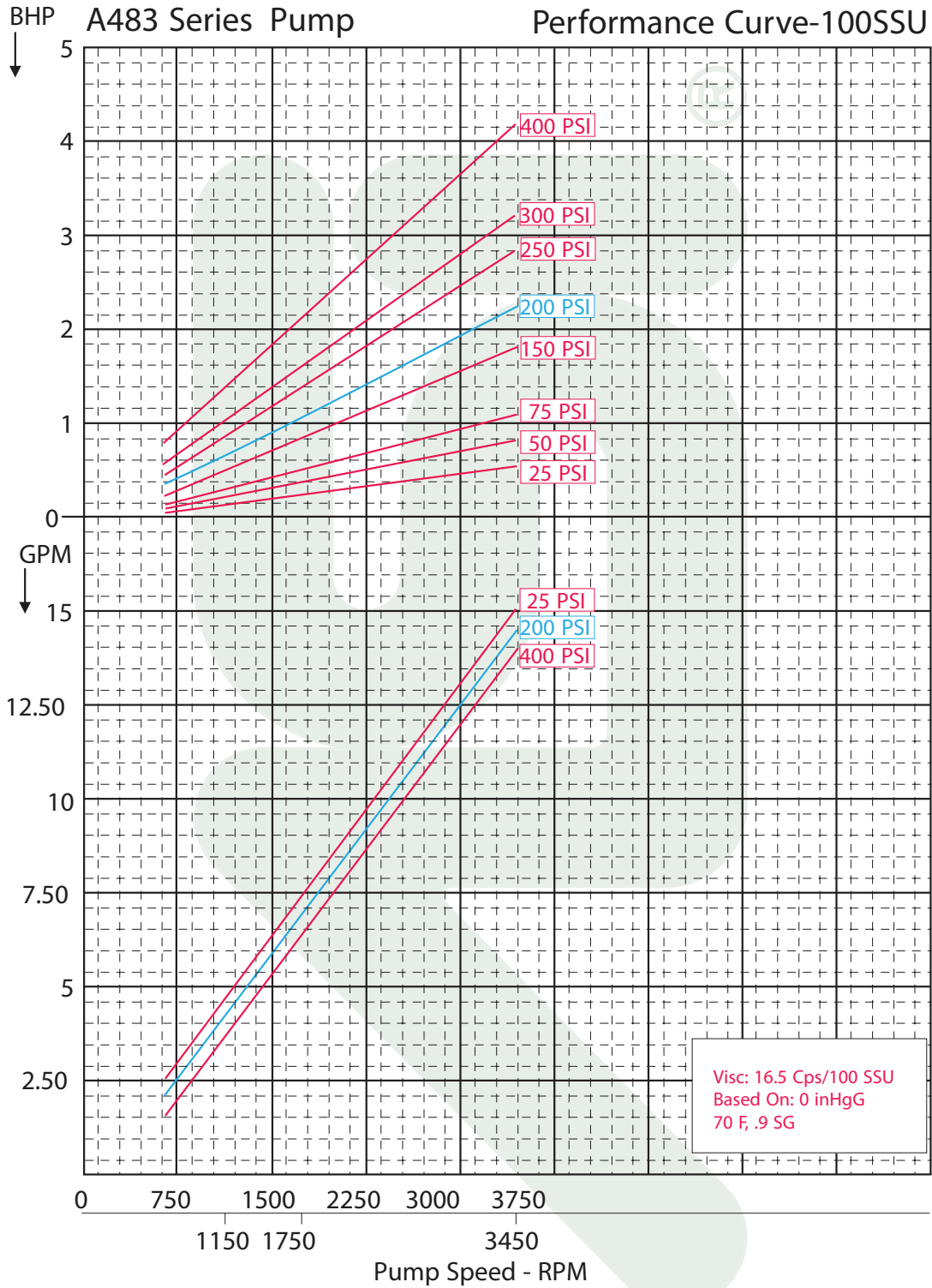

## DF-A483-T / DT-A483-T / DTP-A483-T

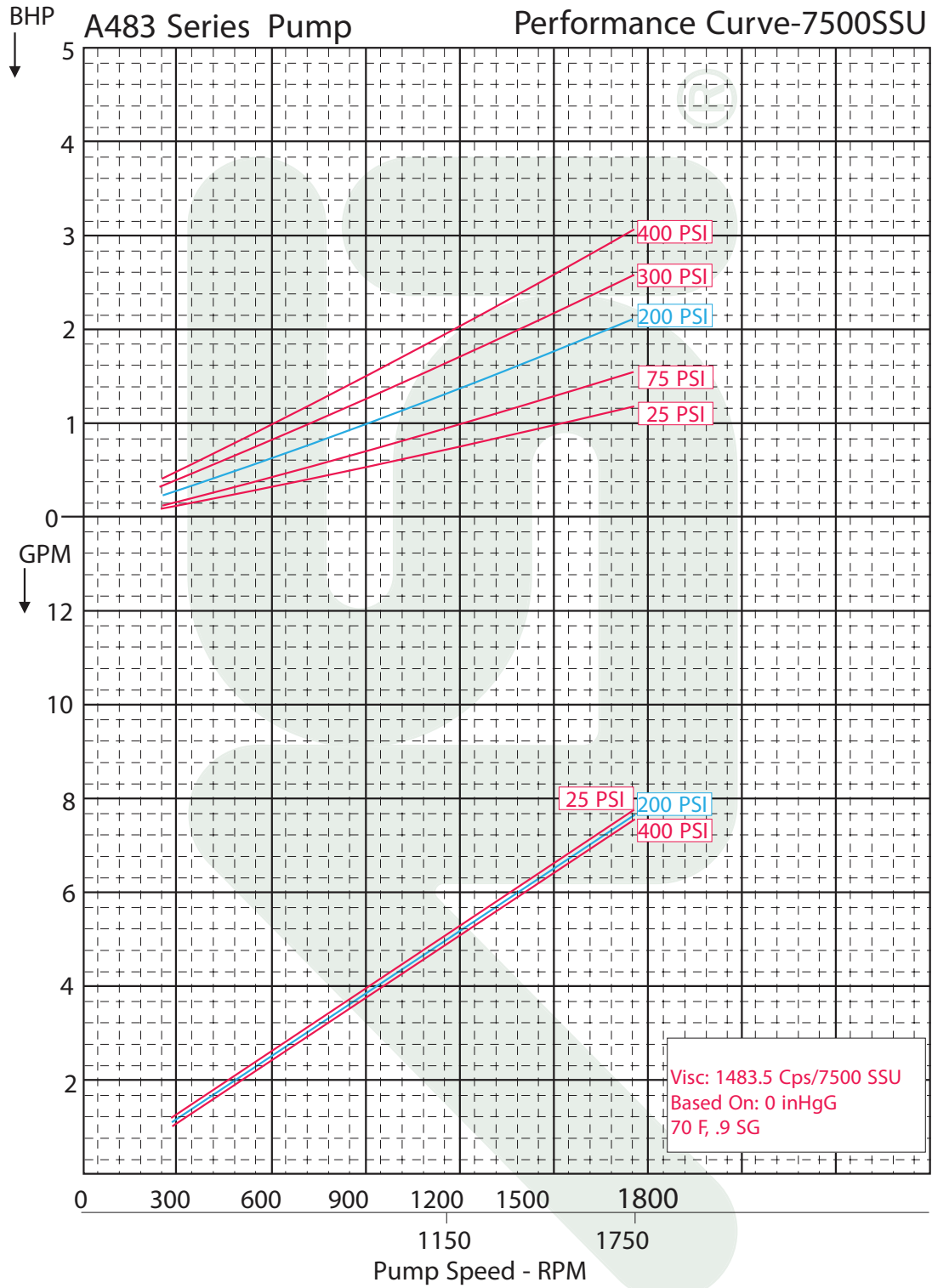

## ASI Pump Warranty

Additive Systems Inc. warrants pumps manufactured by ASI to be free from defects in workmanship or material for a period of one (1) year\* from date of startup, provided that in no event shall this warranty extend more than eighteen (18) months from the date of sale. Pumps manufactured by ASI carry a “no-leak” guarantee which extends for three (3) years from date of purchase. If during said warranty period, a pump proves to be defective in workmanship or material under normal\* use and service, and if such products are returned to ASI in Broken Arrow, Oklahoma, transportation charges prepaid, and if the product is found by ASI to be defective in workmanship or material, they will be replaced or repaired free of charge, F.O.B. Broken Arrow, OK.

\*Pumps utilized for other than normal service, will be warranted for a period of ninety (90) days from date of startup. Please reference the chart on page 2 to identify the right pump for your application.

ASI assumes no liability for consequential damages of any kind and purchaser by acceptance of delivery assumes all liability for the consequences of the use or misuse of ASI products by the purchaser, his employees or others. ASI will assume no field expense for service or parts unless written authorization for it is received in advance.

This is ASI’s sole warranty and is in lieu of all other warranties, expressed or implied, which are hereby excluded, including in particular all warranties of merchantability or fitness for a particular purpose. No officer or employee of Additive Systems Inc. is authorized to alter this warranty.

### **\*Disassembly of Pump Voids Warranty\***

|               |  |                |  |
|---------------|--|----------------|--|
| Serial Number |  | Date Installed |  |
| Serial Number |  | Date Installed |  |
| Serial Number |  | Date Installed |  |
| Serial Number |  | Date Installed |  |

## **Products**

- Custom fabricate to your spec' in steel, aluminum, SS, etc.
- Industrial, commercial, agricultural, residential
- Gasoline, Diesel, Biodiesel, CNG, Ethanol, Jet, Water, etc.
- Turnkey Truck Racks, Blending Skids, Metering Skids
- High Pressure Sampling Pumps
- Leak-Free Magnetically-Coupled Gear Pumps
- SS Hammer Industrial Duty Magnetically-Coupled Pumps
- Tanks built to virtually any size
- OSHA Standards, NFPA Specifications
- Custom Vent Hatches
- Mercaptan Injection Systems
- Desiccant Filters, Specialty Breathers
- Additive Monitoring and Management Systems
- Custom containment pans
- Ladders, Platforms, Cages
- Mechanical Gauges
- "Red-line" Tank Gauges

## **Service**

- Turnkey Installation of Additive Equipment
- Quality Preventative Maintenance Programs
- Complete System Calibration
- Retrofit Installation of existing equipment
- General Maintenance
- Complete CAD Services and Design
- Systems Replacement and Upgrades
- Over 250 Years Combined Employee Experience
- Guarantee the Job Is Done Right
- Tailored jobs for specific requirements

