



Hammer Injection Block Installation & Operation Manual



***Disassembly of ASI Hammer Injection Block
Voids Warranty***



ADDITIVE SYSTEMS INC.
407 S. Main St • Broken Arrow OK, 74012
www.additivesystems.com
1-800-324-1420
"Since 1984"



STANDARD FEATURES

- Stainless steel machined manifold block.
- 3/8" FNPT inlet and outlet connections machined into block.
- Oval gear meter machined into manifold block.
- High resolution gears 5200 pulses per gallon output.
- Meter accuracy of 0.5%.
- Meter repeatability 0.25%.
- Oval Gear material 316 Stainless Steel.
- Gear pinion shafts of Carbide tool steel.
- Explosion proof Hall-Effect meter sensor.
- Sensor is 3-wire type with power (12VDC), common, and pulse signal connections.
- 3/8" FNPT Calibration port with standard quick disconnect coupler.
- Built-in strainer
- Built-in check valve
- Inlet and outlet isolation and throttling valves.
- ASCO[®] Solenoid 120 VAC (120/60hz , 110/50hz)**
 - Solenoid is UL or Cenelec Class I, Div I machined into manifold block.
 - Max 400 PSI working pressure.
 - Max 150 PSI differential pressure.
 - Solenoid Chemraz seat standard.
 - ** Option: ASCO[®] Solenoid 240 VAC (240/60hz , 220/50hz)

Optional Accessories

- Calibration kit, including quick-coupler (female), cylinder, back pressure check valve, and spout. (ASI HB-200)
- New and improved calibration port quick-coupler (male). (ASI HB-109)
- Inlet and outlet isolation/flow control locking needle valves. (ASI HB-101)
- Inlet strainer (100 Mesh). (Call to order)
- Inlet manifolds for 2-pak thru 8-pak. (Call to order)
 - Up to 8 slave hammer injection blocks can be mounted, pumbed and wired for A/C + D/C on mounting back board.

****See Page 14 for complete list of spare parts & accessories.***

FUNCTIONAL DESCRIPTION

The ASI Hammer Injection Block manifold is a low cost solution to chemical additive injection in the petroleum terminal environment. This manifold design meets all of the normal requirements for metering and control of a cyclical injection chemical stream. The ASI Hammer Injection Block provides an electrically operated solenoid valve and a precision fluid meter in a common manifold. In addition, the manifold includes inlet and outlet isolation valves, an inlet strainer, and an outlet check valve. Combining this functionality into a single monolithic manifold block reduces the size of the instrumentation. This is critical in the limited spaces available on truck loading racks today. Additionally, combining the solenoid, meter, and test port into a single manifold eliminates most potential leak points common to stick built manifolds assembled in the field.

This manifold block provides the physical instrument needed to allow a Terminal Automation System, Preset, or PLC System to directly control chemical additive injection. This manifold does not include the electronics control necessary to pace the chemical to a flowing fuel stream, nor does it contain the logic necessary to accumulate additive volume passing through it.

AC line voltage is typically used to energize the solenoid valve and allow flow. The controlling device then accumulates flow volume in the form of pulses transmitted from the meter sensor. When sufficient volume of additive chemical has moved through the manifold, the controlling device then turns off the solenoid valve in order to stop flow. It is the responsibility of the controlling device, Terminal Automation System, Preset, or PLC System, to perform the algorithms necessary to ratio the chemical properly into the fuel stream. Functionality for recipe, injection interval, tolerance, alarm annunciation, shutdown, etc. all are the responsibility of the controlling system. If the controlling system is not capable of this level of function, manifold blocks alone are not the solution. The user should consult our factory for information on complete injection panels that include microprocessor based controllers having the capability of complete injection control.

MOUNTING

The ASI Hammer Injection Block manifold may be mounted in any orientation provided the gear axles remain horizontal. The inlet and outlet ports can be up, down, left, or right. The arrowed line in the sketch below depicts the horizontal axis of the gear axles in the block. When choosing a mounting position, make certain that the arrowed line remains oriented horizontally.

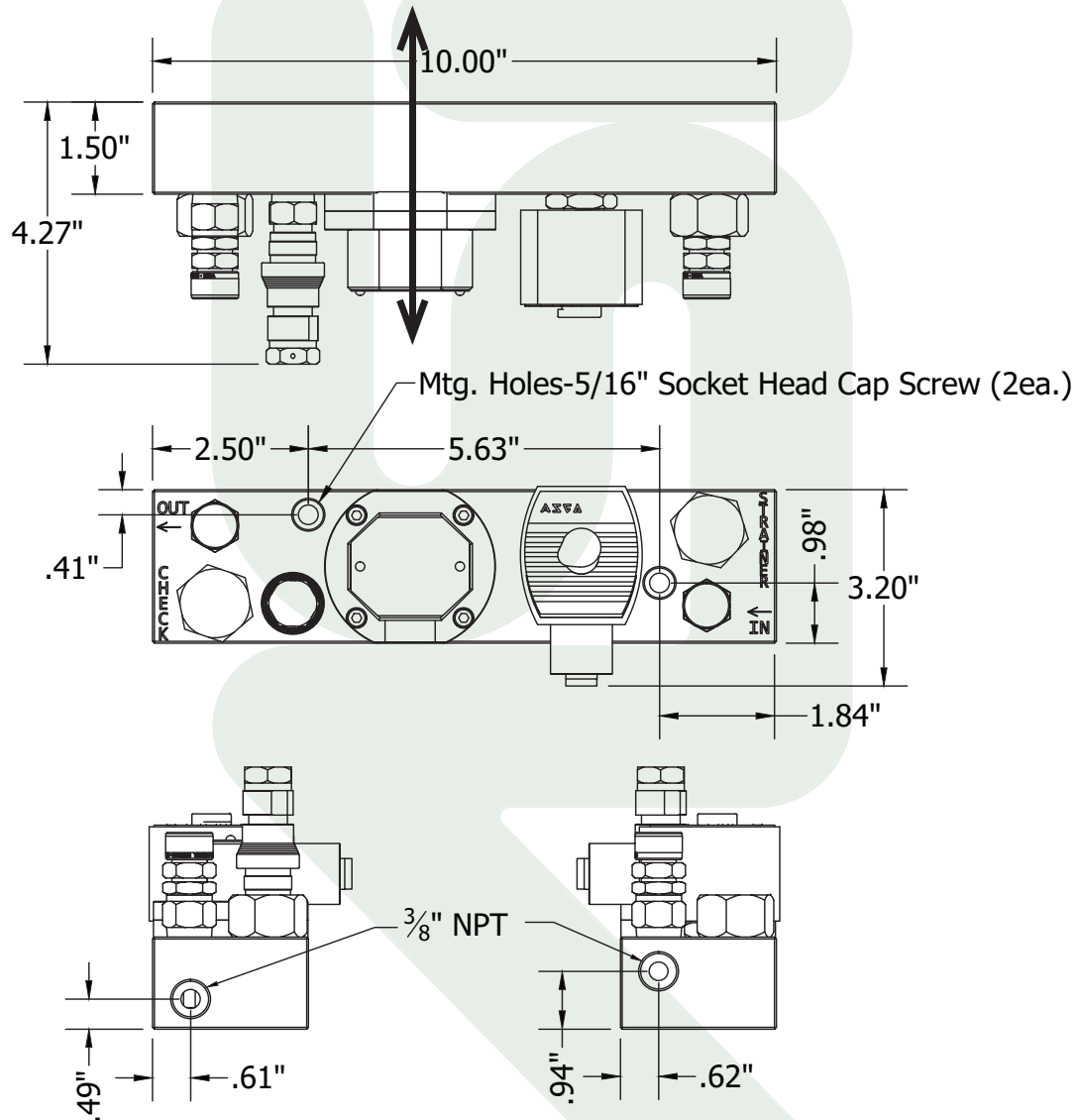

SOLENOID INPUT

The ASI Hammer Injection Block manifold has a single control input. That input is the electrical connections to the actuator coil of the solenoid valve. The coil is typically operated from AC line voltage and frequency common to the area of the world into which the block is sold.

The solenoid valve is normally closed. This means that when the coil is de-energized (no voltage applied) the valve is closed. Applying the rated voltage to the coil opens the fluid flow path through the ASI Hammer Injection Block.

SENSOR OUTPUT

The ASI Hammer Injection Block meters the fluid flowing through it. Two high precision oval gears are mounted in a measuring chamber machined into the block. As fluid passes through the measuring chamber, the fluid force rotates the gears. Imbedded into the gears are four high field strength rare earth magnets. As the gears rotate, these magnets pass beneath a Hall-Effect pickup mounted in the sensor housing. The magnetic field from the gear magnets causes the Hall-Effect pickup to change state (off-on-off) as each magnet passes. Approximately 5200 pulses are generated for each gallon of fluid passing through the meter. The customer's equipment is responsible for providing a means of calibration of the meter. That is, a method of determining the exact number of pulses per gallon, liter, etc. of fluid. This calibration factor is normally referred to as the "K-Factor" for the meter. The k-factor is then used by the customer's equipment for conversion of pulses received to volume dispensed.

WIRING

Solenoid

The solenoid wiring should be a minimum of #16 AWG, type THHN or THWN wire. Good practice dictates AC and DC wiring should be ran in separate conduits for extended distances. Follow local, state, and federal codes and practices applicable to your area.

WARNING: *The solenoid coil presents an inductive load to the switching device controlling it. High counter EMF voltages may be produced when removing the voltage source from such loads. Steps should be taken to ensure these high surge voltages are properly dissipated or equipment damage to the controlling device may occur. Consult with the manufacturer of the controlling equipment for guidance regarding the control of inductive loads. Triac switching is recommended*

Meter Sensor (general)

The sensor wiring can be three conductor, #18-22 AWG shielded instrument cable, with a foil or braided wire shield. Use Belden® number 9363 or similar. Drain or shield wires should be terminated on a DC COMMON or on a specifically assigned shield termination at the controller end only. Do not terminate shields to AC earth ground. Tape off and isolate the shield at the sensor end. Refer to wiring diagrams in this document for specific connection details.

Meter Sensor - Pulse Signal Output

The ASI Hammer Injection Block meter sensor output is an un-sourced, open collector, transistor output. The blue sensor wire is connected to the transistor collector. The emitter of the transistor is connected to the black wire, or DC COMMON connection. The term “un-sourced” means that no voltage is applied to the output from within the sensor. It must be pulled to a ‘high’ or ‘on’ or ‘true’ state by voltage supplied from an external source. The sensor electronics then drives the collector ‘low’ or ‘off’ or ‘false’ with each pulse transmitted. The output is NOT driven high internally within the sensor. This industry common scheme allows the sensor to drive external equipment supplied by its own internal transmitter power. There must be a common connection between the DC negative of the sensor supply and the DC COMMON of the signal accumulating device. Refer to the wiring diagrams at the end of this manual for specific connection details.

ASI Hammer Injection Block

Customer Equipment for Meter Sensor Input

The controlling equipment used for capturing pulses from the ASI Hammer Injection Block may be of two general categories; Un-sourced Inputs, having no voltage present normally on the input connection; Sourced Inputs, having a DC pull-up voltage supplied to the input connection. Two different wiring methods are used for the two types of pulse inputs. Wiring diagrams are provided at the end of this document for each type of input. Refer to the documentation for the controlling equipment for a description of the inputs to determine the type. If the documentation still does not resolve the issue, the following test can be performed.

A digital volt-ohm meter is used to test the equipment input for the presence of voltage. Place the meter in the DC Voltage mode. Disconnect any wires on the DC Pulse Input. Power the controller. Measure the voltage from the DC COMMON terminal (black voltmeter lead) to the DC Pulse Input (red voltmeter lead). If the voltage reading is greater than +5.0 volts, the input is considered a sourced input. If the voltage reading is less than +5.0 volts, the input is considered an un-sourced input. Refer to the corresponding wiring diagram for connections.

Test setup for determining customer equipment input type.

> +5.0 Volts = Sourced Input

< +5.0 Volts = Un-sourced Input

FLUID CONNECTIONS

The fluid inlet and outlet of the ASI Hammer Injection Block manifold is marked with engraved text on the block. The inlet pressure should always be higher than the outlet pressure to ensure proper operation.



Fluid Inlet Piping

Attention should be given to flow dynamics when sizing the tubing, isolation valve, and strainer components feeding the injector inlet. The minimum tubing size for the ASI Hammer Injection Block is ½". Significantly lower flow rates may allow smaller tubing dimensions. Tubing ID should always be smaller than the OD. The isolation valve and strainer size must be increased to handle the flow required for the number of blocks being fed.

Fluid Outlet Piping

Stainless steel tubing is also used for piping the outlet of the ASI Hammer Injection Block manifold to the point of injection.

WARNING: A check valve and an isolation valve ***MUST*** be installed between the manifold and the point of injection! Failure to install an isolation valve will require complete fuel delivery system shutdown in the event of a need for service on the injector manifold. Failure to install a check valve in the line may result in fuel backing up into the additive chemical delivery system and may cause contamination or spill.

Good design practice dictates that an isolation valve, usually a quarter turn ball valve, be installed at the point of chemical injection into the fuel piping. This valve should meet the needs of local policies and practices regarding piping system valves.

An injection point check valve is required. This check valve should be a positive shutoff, spring closed check such as a plug or ball type. A small opening or 'cracking' pressure is acceptable, generally limited to a maximum of 15 PSI. Cracking pressures of 1 PSI and 10 PSI are common in the industry. Ensure the flow characteristic (Cv) of the check valve is adequate to handle the maximum flow rate expected through the injector manifold. Although the location is not critical, it is common practice to place the check valve near the isolation valve at the point of injection.

Remember, pressure differentials across the isolation valve, check valve, tubing, manifold, strainer, etc. all accumulate and ultimately dictate the required supply pump pressure. Minimizing the individual pressure drops allow the lowering of the supply pump pressure and effectively reduces the load and wear on the system.

WARNING: Care should be exercised when connecting multiple injector manifold blocks to one common point of injection. Each manifold line **MUST** have its own check valve to ensure against cross contamination. The length of common piping should be minimized to ensure all additive chemical being injected reaches the fuel line. Not all chemicals are compatible. If multiple additives are used simultaneously, be certain to size common piping for the combined flow.

Thermal Expansion Relief

Thermal relief bypass kits are required with the ASI Hammer Injection Block manifold when installed with a point-of-injection actuated valve. This includes a solenoid valve or electric or pneumatic actuated ball valve.

The ASI Hammer Injection Block manifold will stop flow in the reverse direction when the solenoid is de-energized. The check valve in the block prevents reverse flow. When the additive chemical injection system is idle, any fluid expansion that occurs between the block and the point of injection **MUST** be relieved, usually back to additive storage. When designing the pumping system, provision should be made to allow this thermal expansion volume to return to the additive chemical storage tank.

Temperature Min/Max Range

ASI Hammer Injection Block

Maximum operating temperature: 250° F

Minimum operating temperature: 32° F **

** 32° F is from ASCO solenoid valve specifications. We have customer applications that have operated to as low as 0° F.

If you need to operate in colder temperatures, please consider options for heat trace, insulation and/or enclosures.

SPECIFICATIONS

EQUIPMENT CONNECTIONS

Solenoid		
Two Red Wires	-	Actuator Coil
Green Wire w/ Yellow Stripe	-	Earth Ground

Meter Pickup Sensor

(3-wire, Hall-Effect pickup)

Red Wire	-	Sensor Power
Black Wire	-	Power & Signal Common
Blue Wire	-	Pulse Signal
Certifications:	-	UL® Listed Hazardous locations

Fluid

Inlet	-	3/8" Female NPT
Outlet	-	3/8" Female NPT
Test Portal (normally plugged)	-	3/8" Female NPT

SOLENOID

General Data:		
Fluid Orifice Size:	-	5/32"
Max Working Pressure:	-	400 PSI
Max Operating Pressure:	-	150 PSI (differential)
Certifications:	-	UL® Listed 106A, CSA®

Coil Data:

Power Req.:	-	17.1 Watts @ 120 VAC, 8.6 Watts @ 240 VAC
Certifications:	-	NEMA Type 3, 35, 4, 4X, 6, 6P, 7, & 9 Explosion Proof

ASI Hammer Injection Block

Installation Process & Instrumentation Diagram (P&ID)

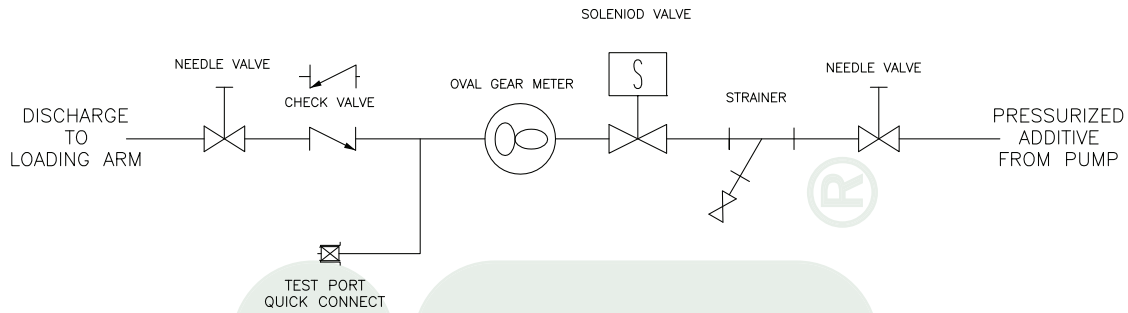

METER & PICKUP SENSOR

Manifold Block Physical:

Fluid Port Sizes:	-	3/8" FNPT
Material (Body):	-	Stainless Steel
Material (Elastomers):	-	Teflon
Max Working Pressure:	-	400 PSI

Fluid Metering Gears:

Nominal Pulse Resolution:	-	5200 pulses per gallon (US) in water (Half Height Gear)
Material (Gears):	-	Stainless Steel

Sensor Physical:

Sensor Thread:	-	1/2" NPT threads, female
Material:	-	Aluminum
Enclosure:	-	Factory Sealed

Sensor Electrical:

Type:	-	Solid-state, bi-polar magnetic gated, open collector output
Sensor Power:	-	5vdc to 30vdc, 20 mA maximum
Open Collector Output:	-	5vdc to 30dc, 100 mA maximum (un-sourced)
3-wire Connection		
Red Wire Function:	-	Sensor power
Black Wire Function:	-	Sensor power common & emitter (signal common)
Blue Wire Function:	-	Sensor signal, open collector output (un-sourced)

ELECTRICAL CONNECTION DRAWINGS

SENSOR LEAD IDENTIFICATION

HAMMER BLOCK SENSOR CIRCUIT

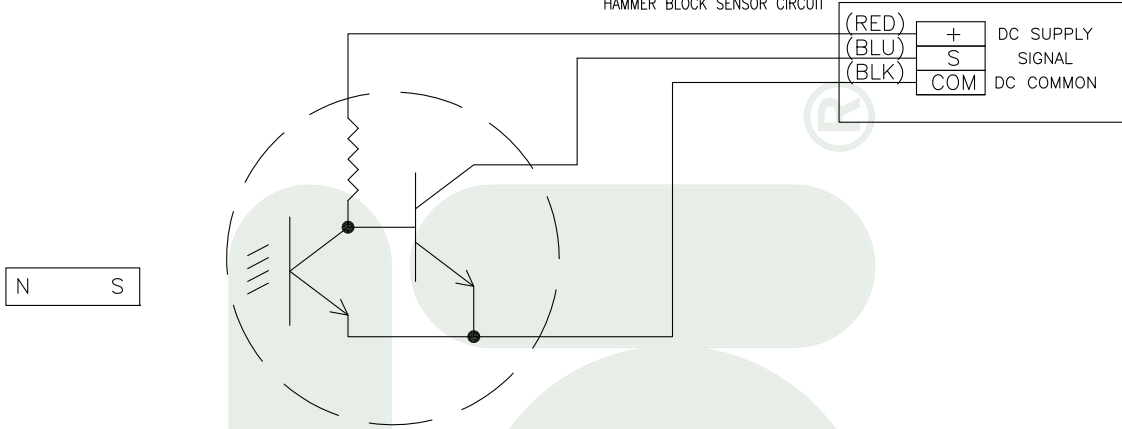

WIRING DIAGRAM FOR SOURCED INPUTS

HAMMER BLOCK SENSOR CIRCUIT

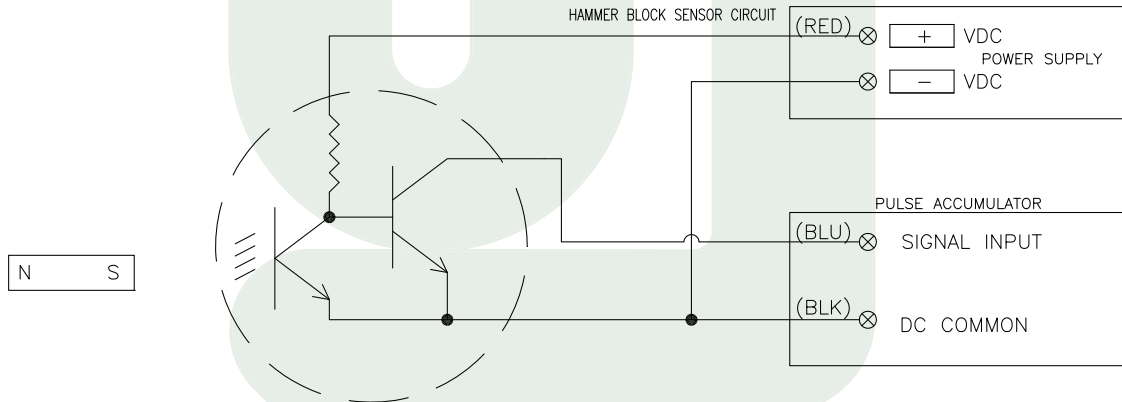

NOTES:

The power supply pictured above may be a separate supply or part of the controller / additive pulse accumulator electronics.

ELECTRICAL CONNECTION DRAWINGS

WIRING DIAGRAM FOR UN-SOURCED INPUTS

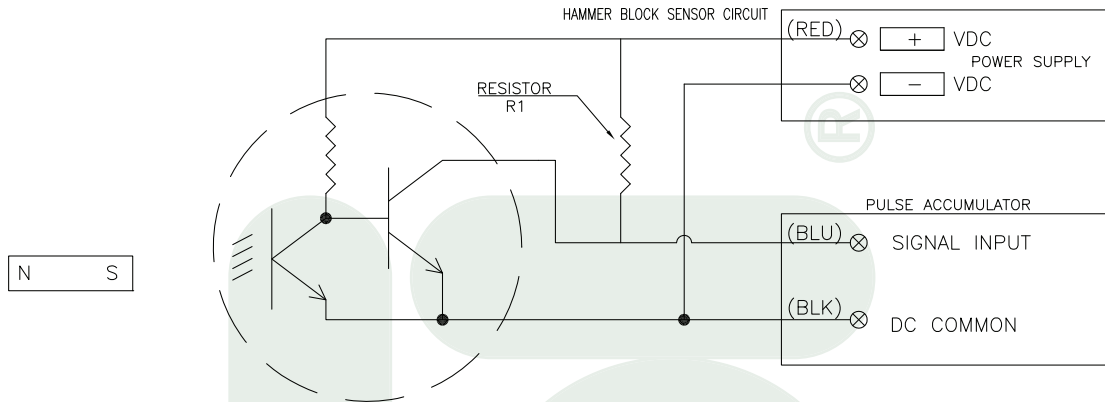

NOTES:

The power supply pictured above may be a separate supply or part of the controller / additive pulse accumulator electronics.

Resistor R1 value varies with the Power Supply voltage.

For 5 - 12 volts use 1500 ohms.

For 12.1 - 18 volts use 2200 ohms.

For 18.1 - 25 volts use 2700 ohms.

For all voltages, ½ watt, 10% or better precision resistors are satisfactory.

Intrinsically Safe ↔ Div. 2 or Non Hazardous
SENSOR LEAD IDENTIFICATION

Intrinsically Safe ↔ Div. 2 or Non Hazardous
WIRING DIAGRAM FOR UN-SOURCED INPUTS

NOTES:
The power supply pictured above may be a separate supply or part of the controller / additive pulse accumulator electronics.

Resistor R1 value varies with the Power Supply voltage.
For 5 - 12 volts use 1500 ohms.
For 12.1 - 18 volts use 2200 ohms.
For 18.1 - 25 volts use 2700 ohms.
For all voltages, ½ watt, 10% or better precision resistors are satisfactory.

Intrinsically Safe Device Entry Parameters:

Terminals	U _i	I _i	C _i	L _i	P _i
Red, Blue to Black	24 V dc	250 mA	1 nF	4 μH	1.5
Red to Black	24 V dc	250 mA	1 nF	4 μH	.75
Blue to Black	24 V dc	250 mA	1 nF	4 μH	.75

TABLE 1
U.S. Equipment Associated Apparatus
 $V_{max} \text{ (or } U_i) \geq V_{oc} \text{ or } V_t \text{ (or } U_o)$
 $I_{max} \text{ (or } I_i) \geq I_{sc} \text{ or } I_t \text{ (or } I_o)$
 $P_{max} \text{ (or } P_i) \geq P_o$
 $C_i + C_{cable} \leq C_a \text{ (or } C_o)$
 $L_i + L_{cable} \leq L_a \text{ (or } L_o)$

Telemetering Equipment for Hazardous Locations use in Class I Division 1 Groups C and D Hazardous Locations
 Model: ASIHB-103, -40°C < T_a < 65°C, T4

Warning: Enclosure contains aluminum. Precautions must be taken to avoid ignition due to impact.
 Warning: Encerme contient en aluminium. Précautions doivent être prises pour éviter l'inflammation due à l'impact.

Maximum cable length from device leads to barrier is 1000 ft.

Multiple Associated Apparatus - Control drawings shall indicate that different associated apparatus must not be connected in parallel unless specifically permitted by the apparatus certification.

Capacitance and inductance of the field wiring from the intrinsically safe equipment to the associated apparatus shall be calculated and must be included in the system calculations as shown in Table 1. Cable capacitance, C_{cable}, plus intrinsically safe equipment capacitance, C_i, must be less than the marked capacitance, C_a (or C_o), shown on any associated apparatus used. The same applies for inductance (L_{cable}, L_i and L_a or L_o, respectively). Where the cable and inductance per foot are not known, the following values shall be used: C_{cable} = 60pF/ft, L_{cable} = 0.2μH/ft.

Associated apparatus must be installed in accordance with its manufacturer's control drawing and Article 504 of the National Electrical Code (ANSI/NFPA 70) for installation in the United States, or Section 18 or the Canadian Electrical Code for installations in Canada.

Continued on Page 2...

Sensor Control Drawing UL

SCALE NTS	DATE 01/23/15	EDIT DATE 03/11/15
No revision to this drawing without prior UL approval		
ASI Additive Systems Inc. Broken Arrow, OK.		DRAWN BY JF
UL FILE # E472546	Drawing # 823415	Rev. 1

When required by the manufacturer's control drawing, the associated apparatus must be connected to a suitable ground electrode per the National Electrical Code (ANSI/NFP 70), the Canadian Electrical Code, or other local installation codes, as applicable. The resistance of the ground path must be less than 1 ohm.

Where multiple circuits extend from the same piece of intrinsically safe equipment to associated apparatus, they must be installed in separate cables or in one cable having suitable insulation. Refer to Article 504.30(B) of the National Electrical Code (ANSI/NFPA 70) and Instrument Society of America Recommended Practice ISA RP-12.6 for installing intrinsically safe equipment.

Associated Apparatus must not be used in combination unless permitted by the associated apparatus certification.

Control equipment must not use or generate more than 250 V rms or dc with respect to earth.

Warning:
Caution should be observed when copper or copper alloys are used for enclosures in atmospheres containing acetylene due to the potential formation of acetylides on the surface that can be ignited by friction or impact. The risk of ignition can be reduced by coating the copper or copper alloy with tin, nickel, or by other coatings, or by limiting the maximum copper content of the alloy to 30 percent.

Certified Standards
UL 913 8th Ed.
CAN/CSA C22.2 No. 157-97 (Reaffirmed 2012)

**Exia
Intrinsically Safe
SÉCURITÉ INTRINSÈQUE**

Warning:
SUBSTITUTION OF COMPONENTS MAY IMPAIR INTRINSIC SAFETY
LA SUBSTITUTION DE COMPOSANTS QUI RISQUERAIENT DE SÉCURITÉ INTRINSÈQUE



Sensor Control Drawing UL

SCALE NTS	DATE 01/23/15	EDIT DATE 03/11/15
No revision to this drawing without prior UL approval		
 Additive Systems Inc. Broken Arrow, OK.		DRAWN BY JF
UL FILE # E472546	Drawing # 823415	Rev. 1

Part List			
ITEM	QTY	PART NUMBER	DESCRIPTION
2	2	ASIH-B-101+	NEEDLE VALVE
3	2	ASIH-B-102	DUST COVER W/ CHAIN
4	1	ASIH-B-103+	SENSOR
5	2	ASIH-B-104	HEX CAP
6	1	ASIH-B-105	CHECK VALVE PLUG
7	1	ASIH-B-106	CHECK VALVE SPRING
8	1	ASIH-B-107	TEST PORT STEM
9	1	ASIH-B-108	DUST COVER
10	1	ASIH-B-109	TEST PORT ADAPTER
11	1	ASIH-B-110	TEFLON O-RING
12	2	ASIH-B-111	ENCAPSULATED O-RING
13	1	ASIH-B-112	STRAINER SCREEN
14	1	ASIH-B-113	ASCO VALVE REPAIR KIT
15	1	ASIH-B-114+	SS GEARS (SET)
16	1	ASIH-B-115	ASCO VALVE COIL
17	1	ASIH-B-202	THERMAL RELIEF KIT
18	1	ASIH-B-113ORINGT	ASCO STEM O-RING TELFON

Additional Spare Equipment	
ASIH-B-X1	inj, ASI-Blk loose 538.5
ASIH-B-001	inj, ASI-1Pak 538.5 panel
ASIH-B-002	inj, ASI-2Pak 538.5 panel
ASIH-B-003	inj, ASI-3Pak 538.5 panel
ASIH-B-004	inj, ASI-4Pak 538.5 panel
ASIH-B-005	inj, ASI-5Pak 538.5 panel
ASIH-B-006	inj, ASI-6Pak 538.5 panel
ASIH-B-007	inj, ASI-7Pak 538.5 panel
ASIH-B-008	inj, ASI-8Pak 538.5 panel
ASIH-B-200	Kit, Calb. ASIBlk w/1k beaker
ASIH-B-201	Kit, Inj. ASI Blk Add-a-blk
ASIH-B-202	Kit, Inj. Thrm Relief ASI Blk
ASIH-B-220	Kit, ASI/Honeywell Adpt

ASI Hammer Injection Block

SHOWN WITH OPTIONAL
THERMAL RELIEF KIT
ASIH-B-202

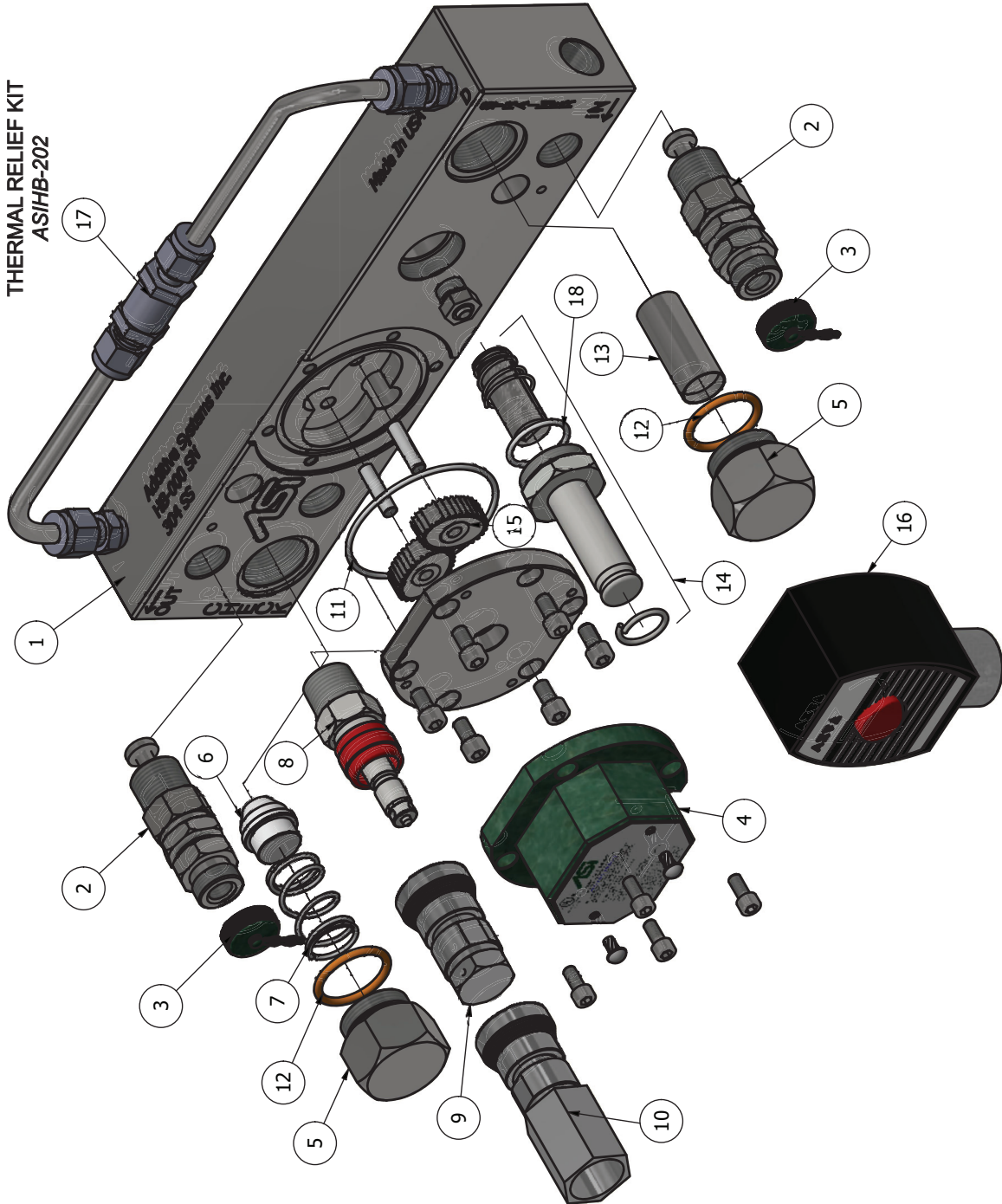

Quality Control Statement

Additive Systems Inc. Broken Arrow, Oklahoma is the owner operated factory where ASI Hammer Injection Blocks are manufactured, assembled and tested.

ASI Hammer Injection Blocks undergo a series of Quality Assurance tests during the course of manufacturing. The Quality Control tests are performed on finished products to verify the initial performance and consistent repeatability of product output units, including performance with special materials, etc. A typical Quality Control test consists of meter accuracy and assured operational power to the pick-up coil. ASI Hammer Injection Blocks are tested as a complete unit before shipping through ASI's distribution warehouse and ultimately the end user.

- Parts manufactured for ASI are accepted to a tolerance of +or-.001”
- ASI Hammer Injection Blocks are leak tested at 500psi for 30 minutes
- Fully assembled ASI Hammer Injection Blocks are tested to a field simulation for 10 gallons at 4 second intervals injections, confirming injection accuracy

ASI Warranty

Additive Systems Inc. warrants the ASI Hammer Injection Block manufactured by ASI to be free from defects in workmanship or material for a period of one (1) year* from date of startup, provided that in no event shall this warranty extend more than eighteen (18) months form the date of sale.

ASI assumes no liability for consequential damages of any kind and purchaser by acceptance of delivery assumes all liability for the consequences of the use or misuse of ASI products by the purchaser, his employees or others. ASI will assume no field expense for service or parts unless written authorization for it is received in advance.

This is ASI's sole warranty and is in lieu of all other warranties, expressed or implied, which are hereby excluded, including in particular all warranties of merchantability or fitness for a particular purpose. No officer or employee of Additive Systems Inc. is authorized to alter this warranty.

Notes:



Products

- Custom fabricate to your spec' in steel, aluminum, SS, etc.
- Industrial, commercial, agricultural, residential
- Gasoline, Diesel, Biodiesel, CNG, Ethanol, Jet, Water, etc.
- Turnkey Truck Racks, Blending Skids, Metering Skids
- High Pressure Sampling Pumps
- Leak-Free Magnetically-Coupled Gear Pumps
- SS Hammer Industrial Duty Magnetically-Coupled Pumps
- Tanks built to virtually any size
- OSHA Standards, NFPA Specifications
- Custom Vent Hatches
- Mercaptan Injection Systems
- Desiccant Filters, Specialty Breathers
- Additive Monitoring and Management Systems
- Custom containment pans
- Ladders, Platforms, Cages
- Mechanical Gauges
- "Red-line" Tank Gauges

Service

- Turnkey Installation of Additive Equipment
- Quality Preventative Maintenance Programs
- Complete System Calibration
- Retrofit Installation of existing equipment
- General Maintenance
- Complete CAD Services and Design
- Systems Replacement and Upgrades
- Over 250 Years Combined Employee Experience
- Guarantee the Job Is Done Right
- Tailored jobs for specific requirements

